

Carrier clip — Radial Insertion machine

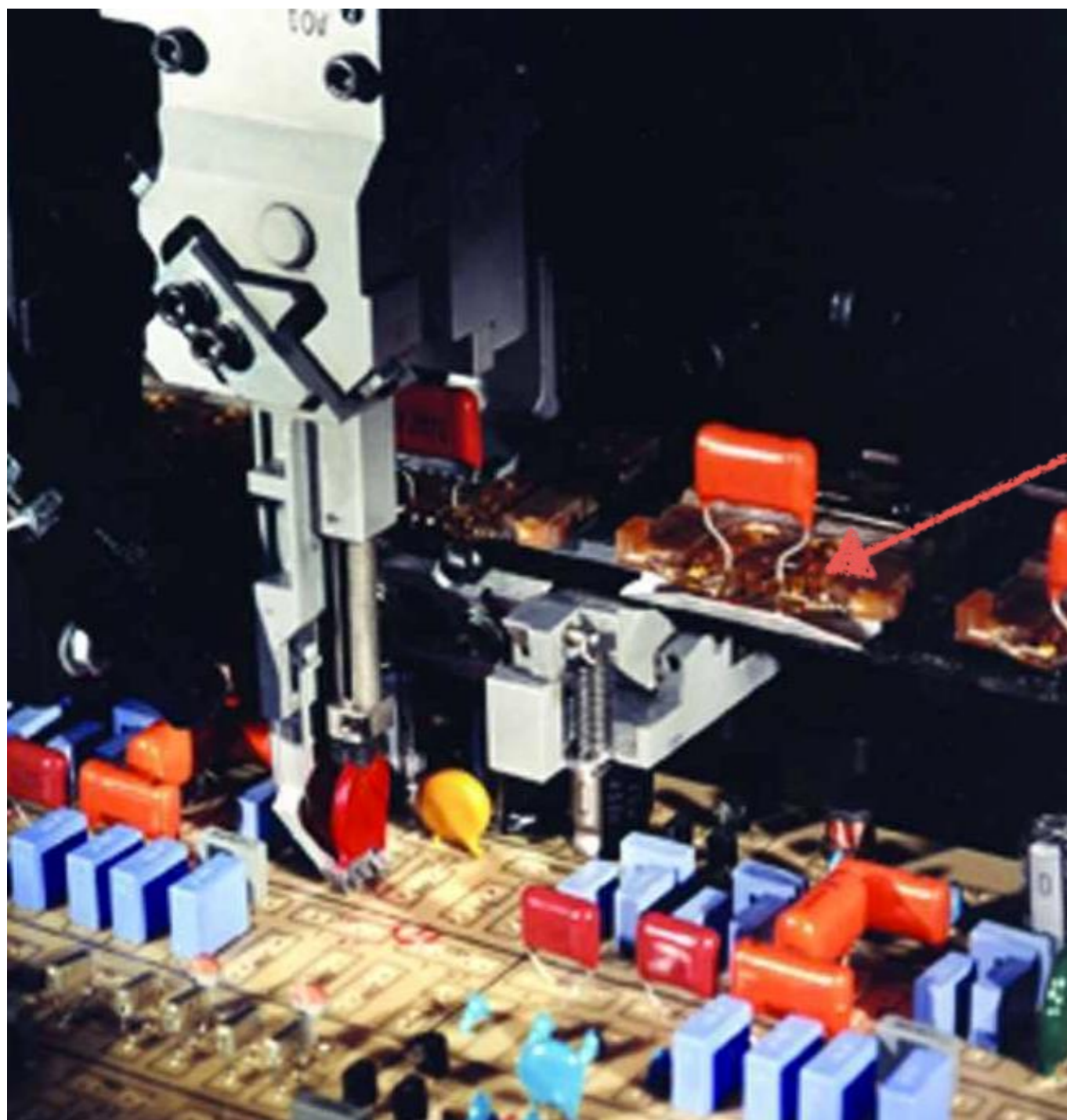

To carrier Radial lead
component from
feeder to insertion head

Carrier clip — Radial Insertion machine

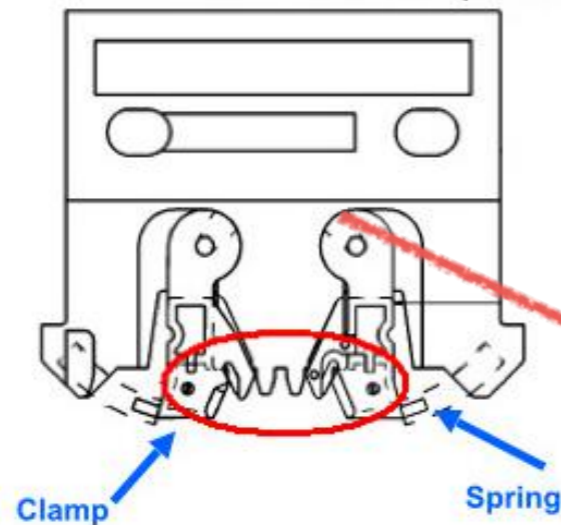

- Holds parts by spring loaded “clamps”
- Clips attach to the “Chain” that runs thru the machine
- The chain indexes 1 chain clip wide each “step” so all clips are used.

Kinds of Clips

New Part Number	Descriptions	Old P/N
4280470L	Carrier Clip Assembly, Single Span (2.5) for LED	
52570301	Carrier Clip Assembly, Dual Span (2.5/5.0)	42804703, 42804704, 42804703X
52556001	Carrier Clip Assembly, small Triple Span (2.5/5.0/7.5)	48820001, 90055421,90054812
52556002	Carrier Clip Assembly, 3.5 Triple Span (2.5/5.0/3.5)	
52556101	Carrier Clip Assembly, Large Triple Span (5.0/7.5/10.0)	48820002,
52532001	Carrier Clip Assembly, Quad Span (2.5/5.0/7.5/10.0)	
52532002	Carrier Clip Assembly, Quad Span (2.5/5.0/7.5/10.0)	

52570301--Carrier Clip Assembly, Dual Span (2.5/5.0)

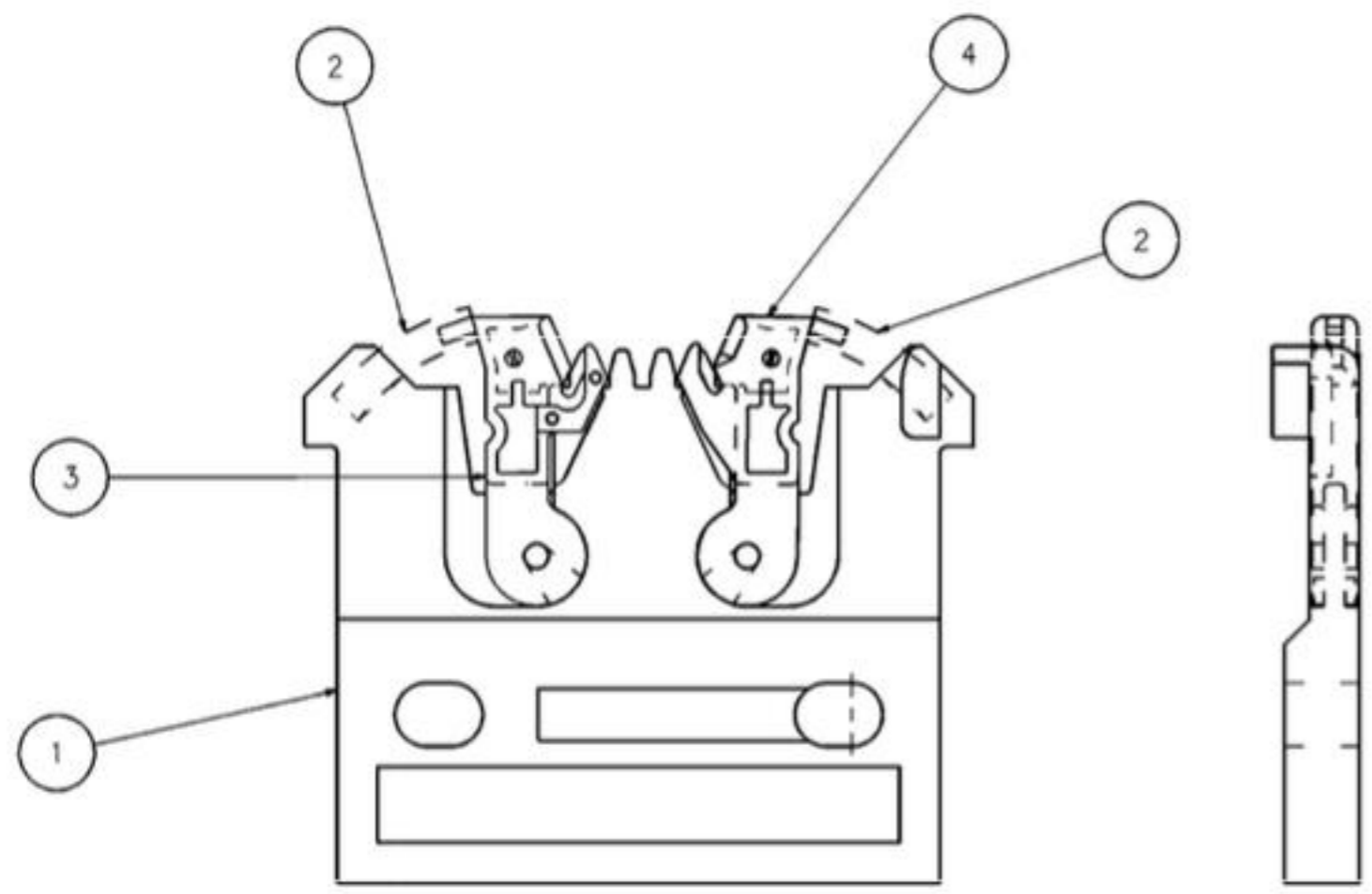



**SOUTHERN
MACHINERY**

52556002--Carrier Clip Assembly, 3.5 Triple Span (2.5/5/3.5)

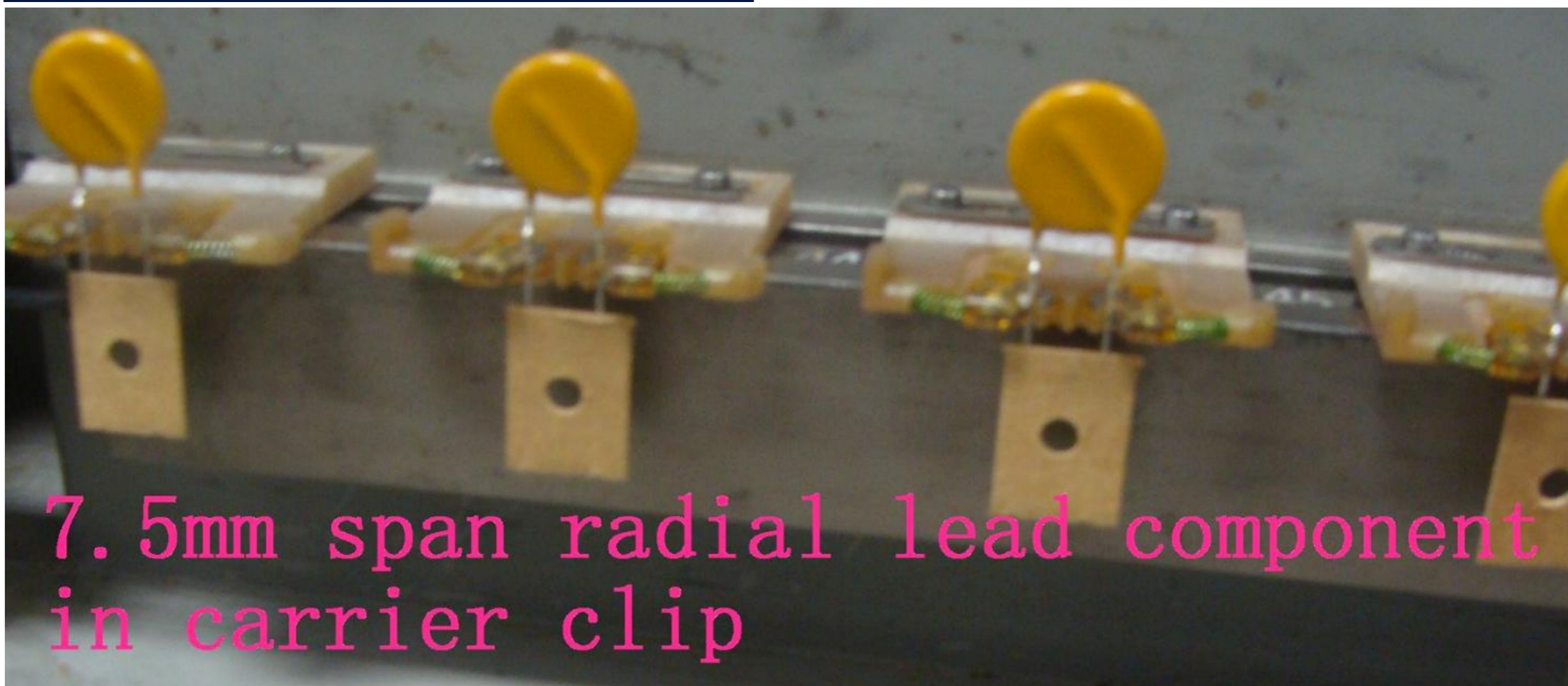
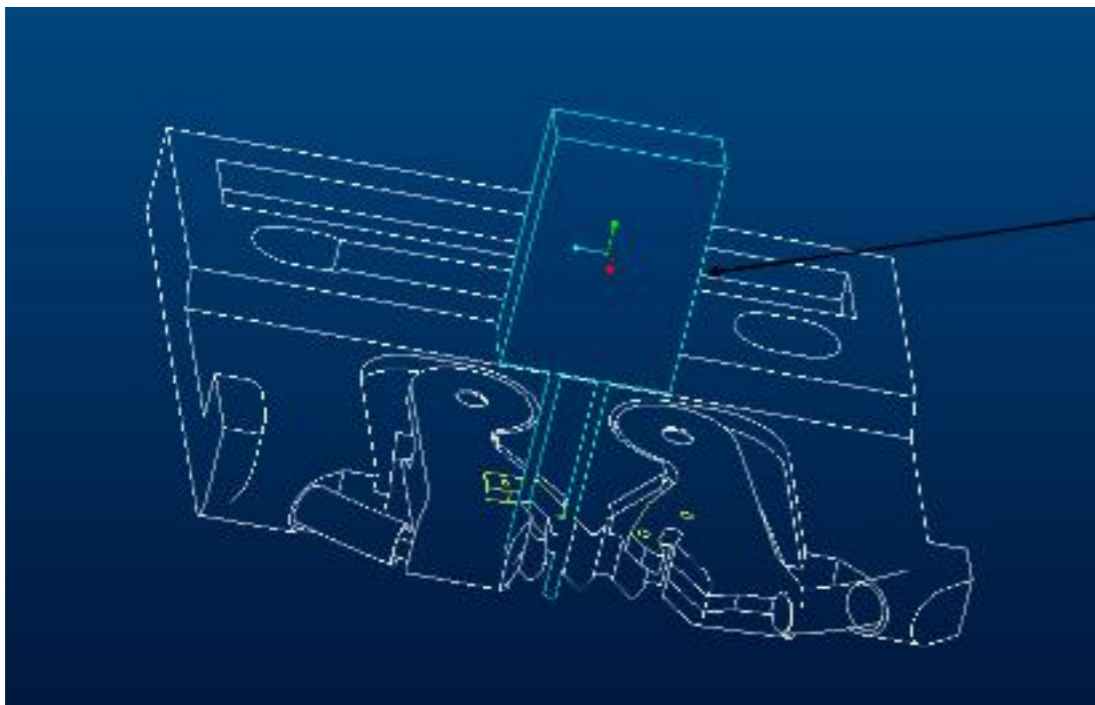

52556101--Carrier Clip Assembly, Large Triple Span (5/7.5/10)

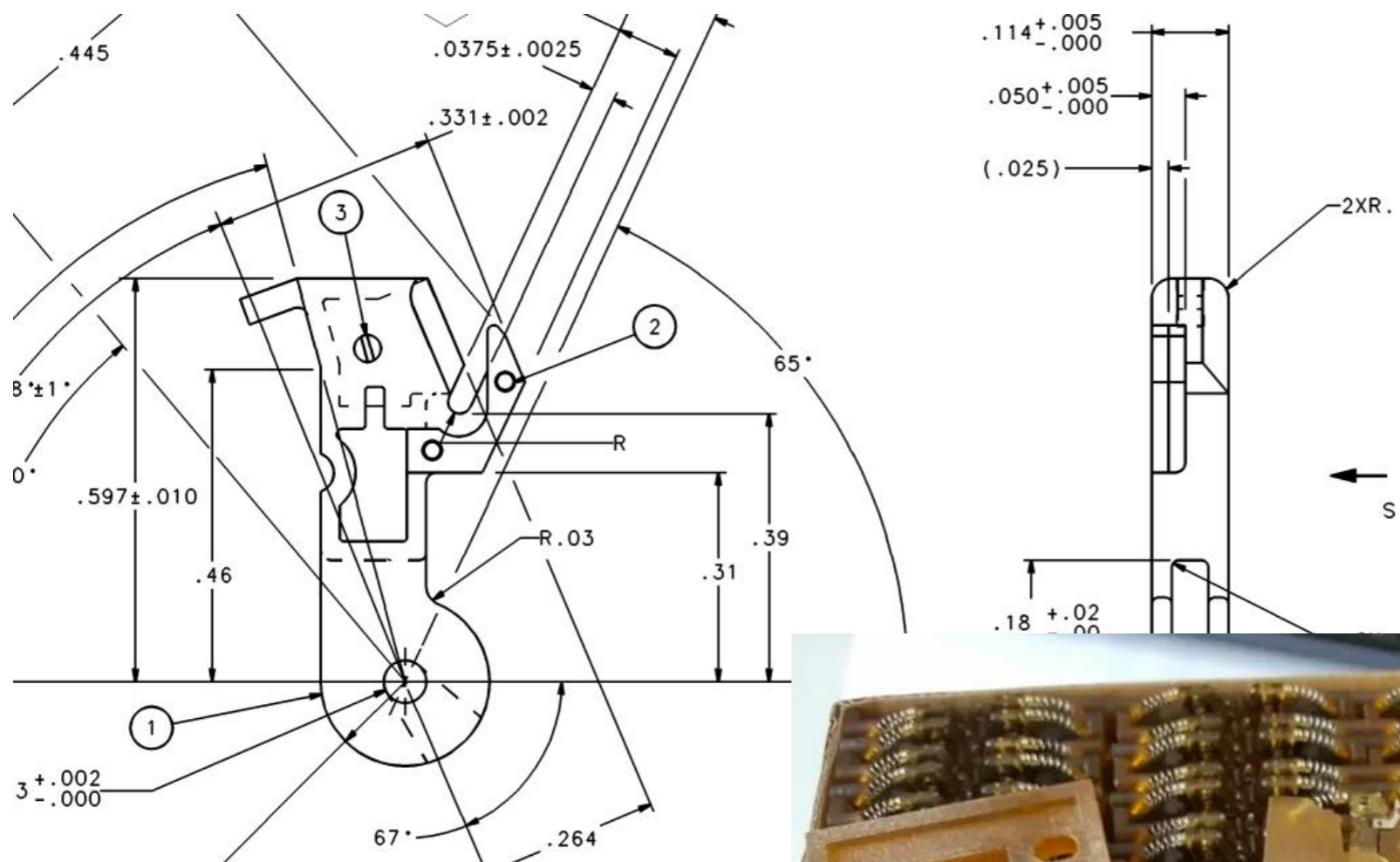

52532001--Carrier Clip Assembly, Quad Span (2.5/5/7.5/10)

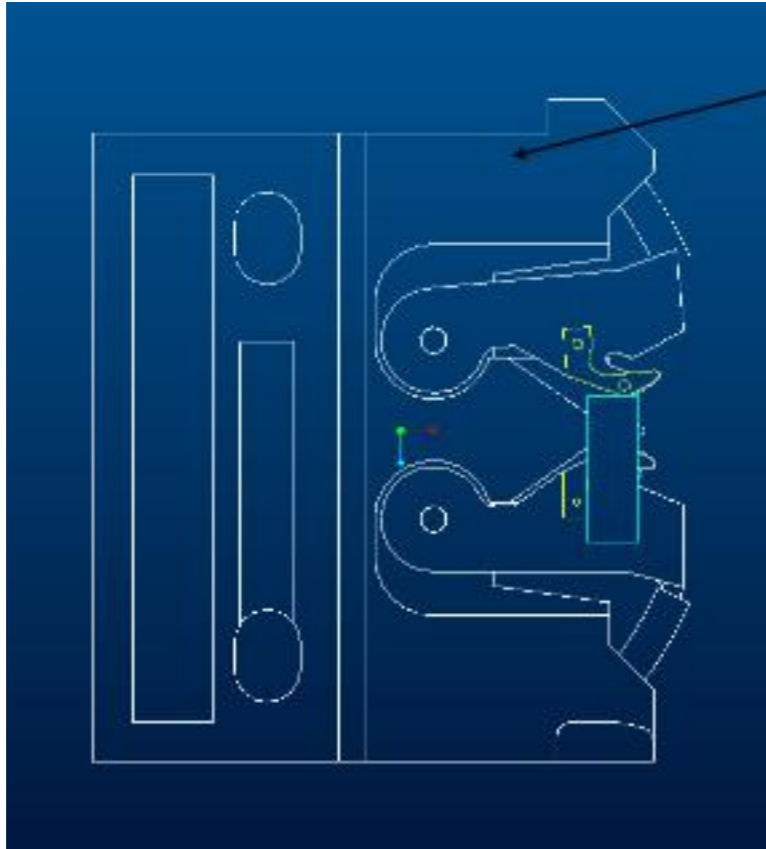

52532001--Carrier Clip Assembly, Quad Span (2.5/5/7.5/10)

52 1/2" Span, Carrier Assy	250	250
52 1/2" Span, Carrier Assy	250	250
52 1/2" Span, Carrier Assy	250	250
52 1/2" Span, Carrier Assy	250	250
52 5/8" Span, Carrier Assy	180	180
52 5/8" Span, Carrier Assy	180	180
52 5/8" Span, Carrier Assy	180	180
52 5/8" Span, Carrier Assy	180	180
52 7/8" Span, Carrier Assy	200	200
52 7/8" Span, Carrier Assy	200	200

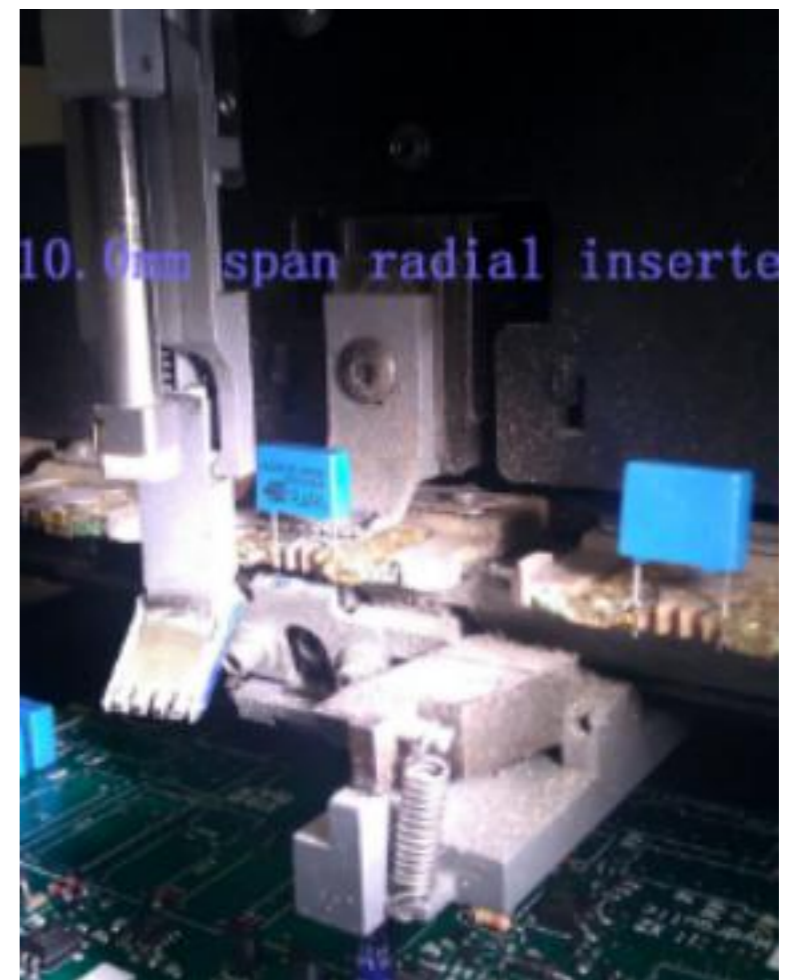
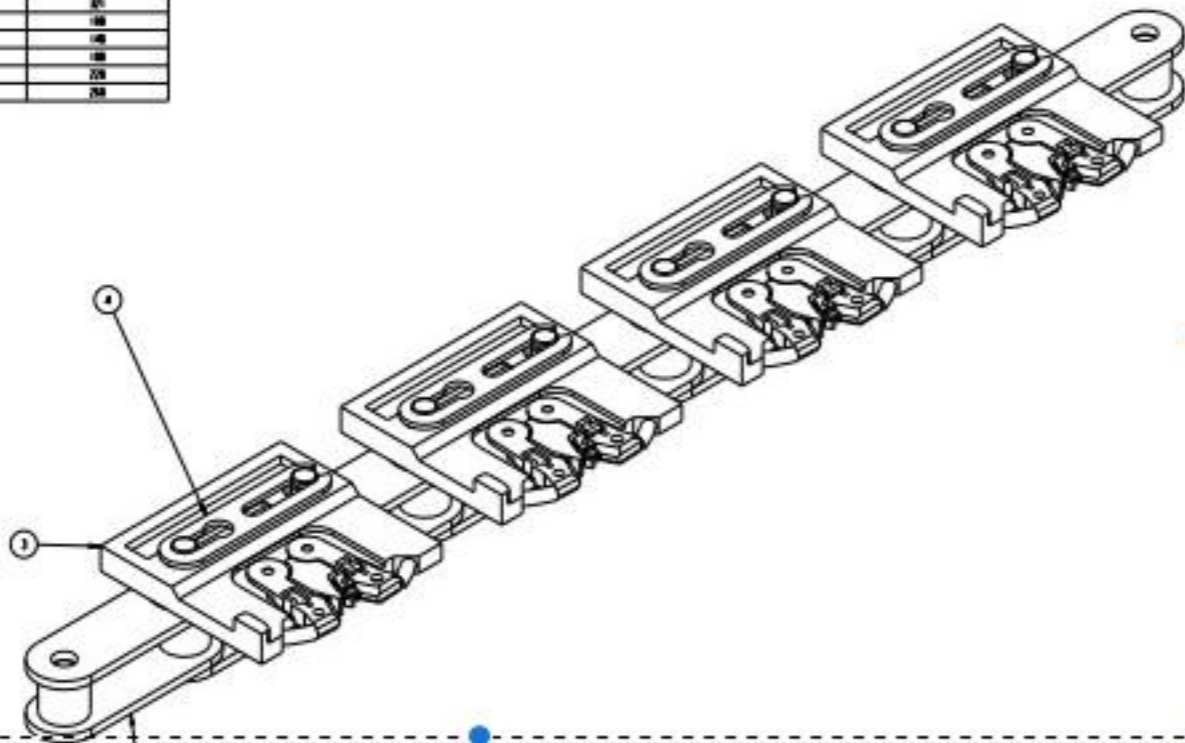

How many Clips in one machine

Machine configuration	Chain -P/N	Carrier Clips Qty
20 Stations Straight back	30371124	108
40 Stations Straight back	30371123	148
60 Stations Straight back	30371122	188
60 Station In line	30371118	241
80 Station In line	30371117	281
80 Stations Straight back	30371121	228



Life Cycle

42804704 Carrier Clip Assembly

Part Number	Description	Life Expectancy (Cycles)
43556203	Clamp, Dual (2 Inserts)	10-30 Million
42718602	Clamp	10-30 Million
42717602	Housing	10-30 Million

The life expectancy of consumables (wear tooling) is dependent on a variety of factors. The work environment (humidity, dust, etc.) is also a factor. A customer may experience greater or less life expectancy depending on the above

Cutter Station to Carrier Clip Alignment

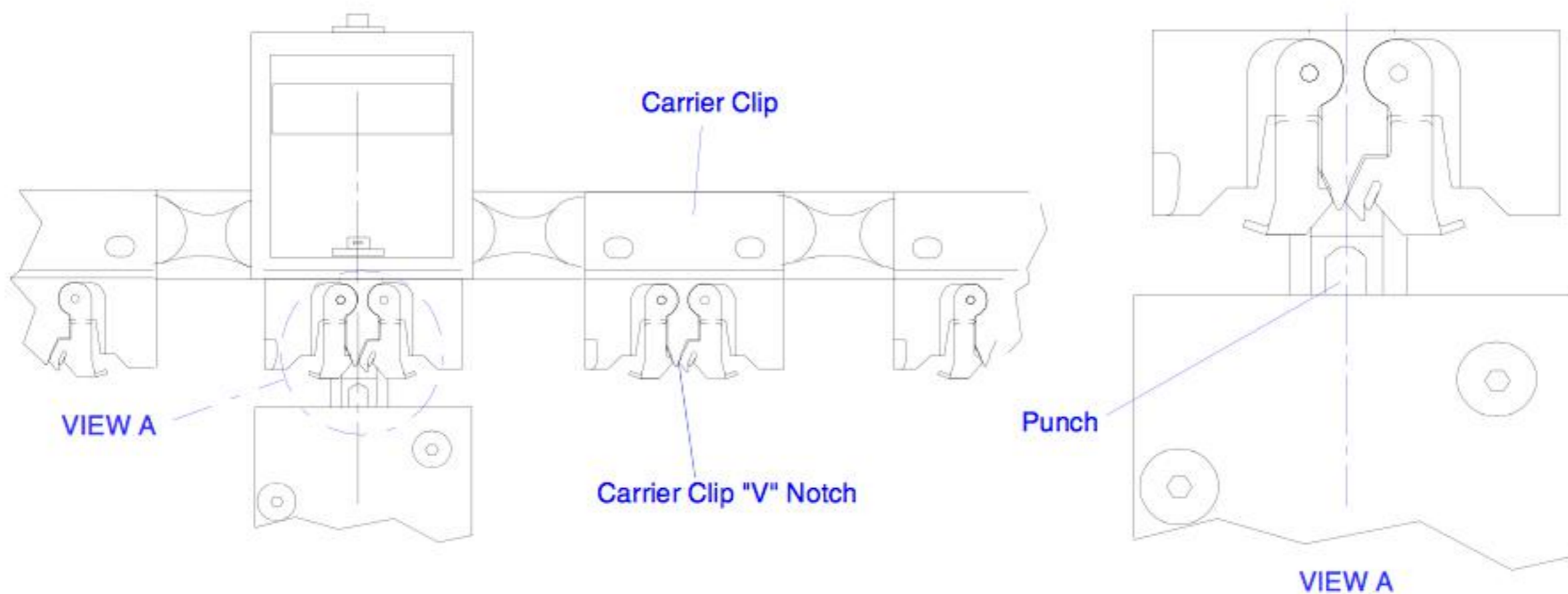

Cost down

- **Proper preventive maintenance.**
- **Proper machine setup.**
- **PC board material.**
- **the type of component used, including lead size, material, and shape.**



Increasing machine throughput

Welcome inquiry

- **Better quality as original**
- **Provide different spare parts and wearing parts of different brands and models.(UIC,TDK,Panasonic,Samsung,Fuji,Juki,Siemens.....)**
- **One day lead-time**
- **After sales service and technical support.**

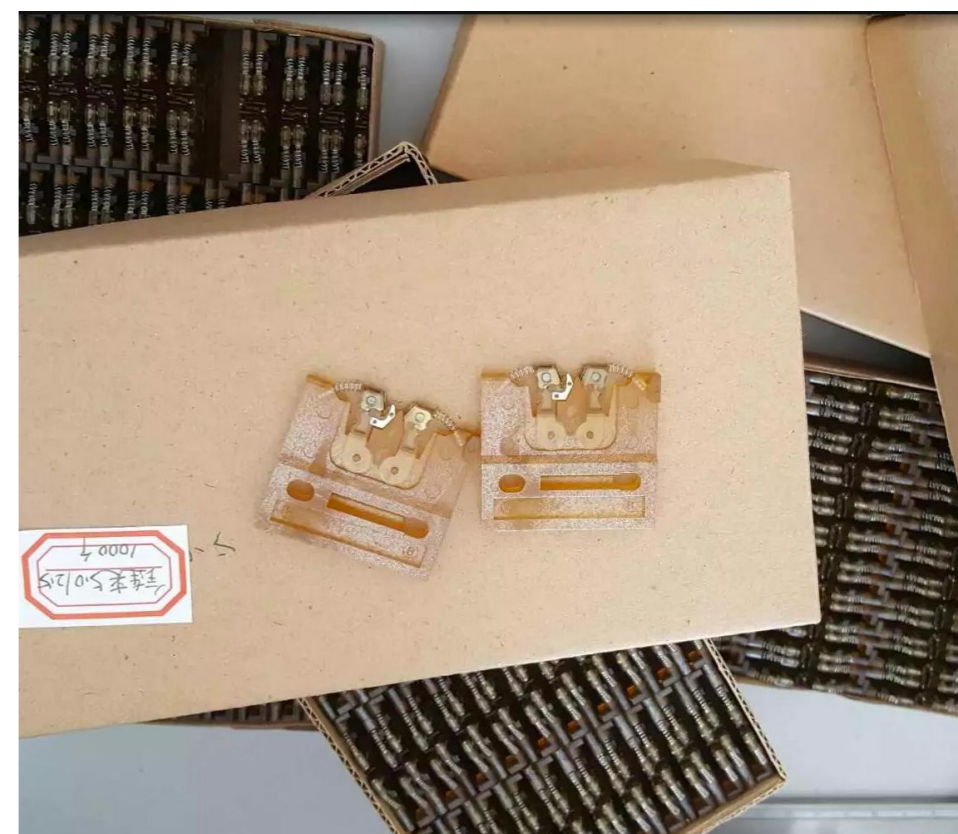

Welcome inquiry

- 1, Please visit : www.smthelp.com
- 2, Find us more: <https://www.facebook.com/autoinsertion>
- 3, Know more our team: <https://cn.linkedin.com/in/smtsupplier>
- 4, Welcome to our factory in Shenzhen China
- 5, See more video in Youtube: Auto+Insertion
- 4, Looking for more informations: jasonwu@smthelp.com